

REV	ZONE	REVISION	DATE

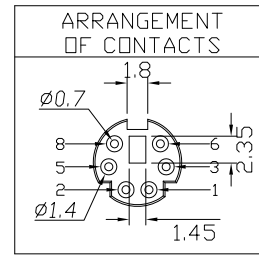

Green Product

Specification:
Contact Resistance: 30m Ohm Max.
Insulation Resistance: 100M Ohm Min.AT 500V DC
Rated Voltage And Current: DC12V.2A Max;AC 100V.1A Max
Dielectric Withstanding Voltage: 250V AC For 1 Minute
Durability (Life Test): 100 Cycles
Insertion Force: 4.0KG Maximum.
Extraction Force: 0.9KG Minimum.

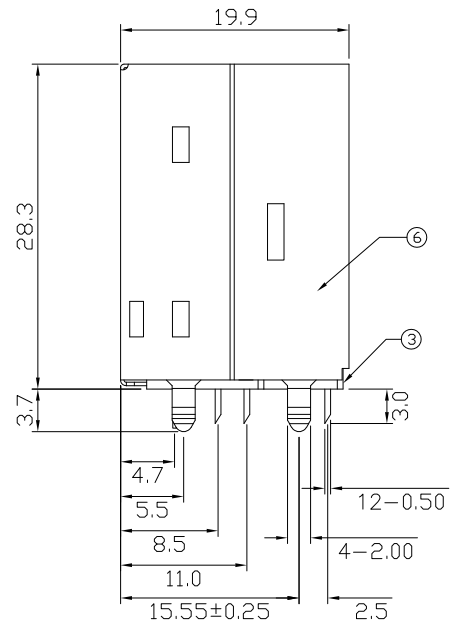
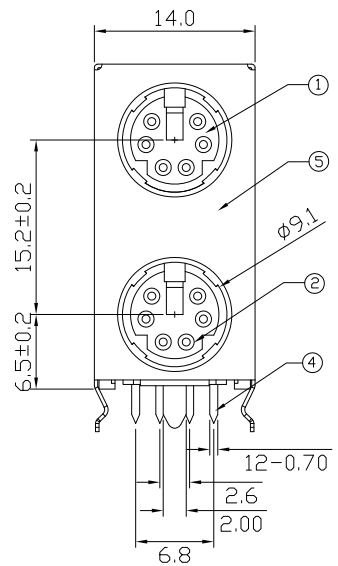
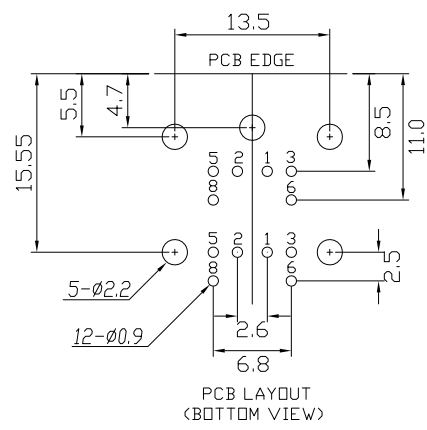

NO.	NAME	MATERIAL	FINISH	REMARK	Q'TY
1	TOP HOUSING	PBT G.F.	GREEN;3395C		1
2	BOTTOM HOUSING	PBT G.F.	PURPLE;2715C		1
3	BACK COVER	PBT G.F.	PURPLE;2715C		1
4	CONTACT TERM.	PHOS. BRONZE T:0.2	GOLD/TIN PLATED	Gold:1~3u"; NI:40~60u"; TIN:120u" (100% pure Tin of lead free plating)	12
5	FRONT SHIELD	BRASS T:0.3	TIN PLATED	TIN:120~200u"	1
6	BACK SHIELD	BRASS T:0.3	TIN PLATED	TIN:120~200u"	1

LEAMAX 易昕企業有限公司
LEAMAX ENTERPRISE CO.,LED.

Drawing No			UNIT	SCALE	TITLE		
3260-001			mm	1:1	MINI DIN JACK DUAL		
APPD.	CKD.	DWG.	DATE	TOLERANCE	PART NO.	REV.	
JAMES 24-11-15	SHIRLEY 02-11-15	TINA 23-04-10	23-04-10	X. ±0.38 .X ±0.25 .XX ±0.13 .XXX ±0.05	3260-06PE	A3	

MODEL 3260-06PE PAGE 1 OF 1