

REV	ZONE	REVISION	DATE

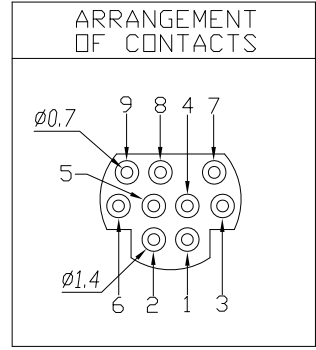

**Specification:** (BOTTOM VIEW)

- Contact Resistance: 30m Ohm Max.
- Insulation Resistance: 100M Ohm Min. AT 500V DC
- Rated Voltage And Current: DC12V.2A Max; AC 100V.1A Max
- Dielectric Withstanding Voltage: 250V AC For 1 Minute
- Durability (Life Test): 100 Cycles
- Insertion Force: 4.0KG Maximum.
- Extraction Force: 0.9KG Minimum.

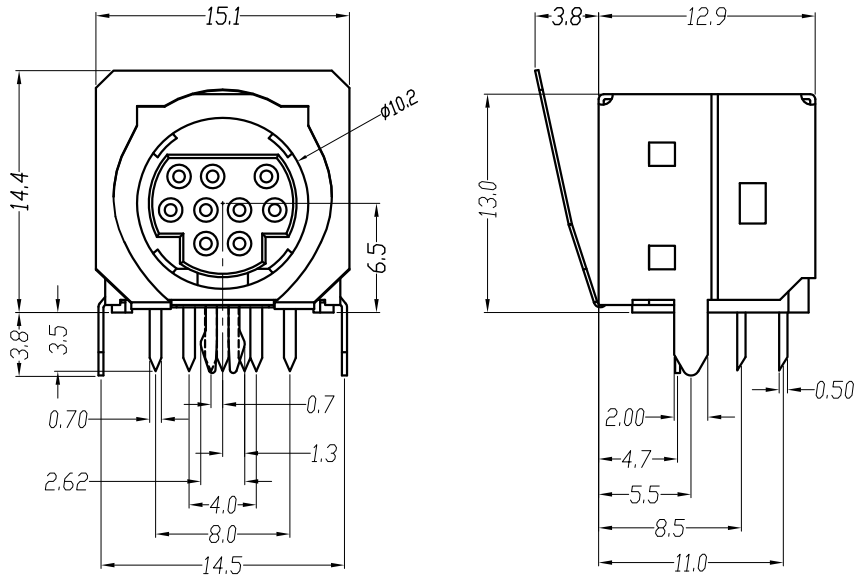
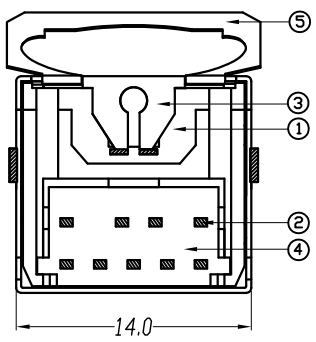

**Green Product**

NO.	NAME	MATERIAL	FINISH	Q'TY
1	HOUSING	PBT G.F.	BLACK	1
2	CONTACT	PHOS. BRONZE T:0.2	Gold:1~3u"; NI:40~60u"; TIN:120u" (100% pure Tin of lead free plating)	9
3	SHIELD	BRASS T:0.3	TIN PLATED Sn:120~200u"	1
4	BOTTOM COVER	PBT G.F.	BLACK	1
5	SPRING SHIELD	STAINLESS T:0.2		1



易昕企業有限公司  
LEAMAX ENTERPRISE CO., LED.

Drawing No			UNIT	SCALE	TITLE		
3266-009			mm	1:1	MINI DIN JACK FLAT 9 PIN DIP		
APPD.	CKD.	DWG.	DATE	TOLERANCE	PART NO.	REV.	
JAMES 01-04-16	SHIRLEY 01-04-16	TINA 08-04-10	08-04-10	X. ±0.38 .X ±0.25 .XX ±0.13 .XXX ±0.05	3266-9SE	A1	

MODEL 3266-9SE PAGE 1 OF 1